

**TEUPEN**<sup>®</sup>  
...access redefined

## TL92SJ

Platform Height:  
91 ft 10 in (28 m)

Lateral Reach:  
45 ft 11 in (14 m)

Machine Width:  
5 ft 3 in (1.58 m)

Machine Height:  
6 ft 6 in (1.99 m)

Machine Weight:  
9,480 lbs (4,300 kg)

- Compact design, travels through a double door
- Light, low surface load for use on sensitive flooring
- Smooth, proportional electro-hydraulic controls
- Reliable and comprehensive safety control system
- Hydrostatic platform leveling
- Onboard diagnostics
- Setup on slopes up to 30%
- Dual power (diesel and A/C electric) for operating indoor and outdoor



**Teupen USA, Inc.**  
PO Box 938  
Pineville, NC 28134  
info@teupen-usa.com

Toll Free - 877 838 7361

[www.Teupen-usa.com](http://www.Teupen-usa.com)

# Specifications

MEASUREMENTS	US	Metric
Platform height, max.	91 ft 10 in	28,00 m
Horizontal outreach with 176 lbs	51 ft 6 in	15,70 m
Horizontal outreach with 441 lbs	45 ft 11 in	14,00 m
Platform height (A)	3 ft 7 in	1,10 m
Platform length (B)	2 ft 8 in	0,80 m
Platform width (C)	3 ft 11 in	1,20 m
Length, overall (D)	23 ft 8 in	7,20 m
Height, travelling position (E)	6 ft 6 in	1,98 m
Width, min. (F)	5 ft 3 in	1,58 m
Ground clearance, max. (G)	11 in	0,27 m
Track (L x W) (H)	6 ft 2 in x 10 in	1,92 m x 0,25 m
Length outrigger footprint standard (I)	17 ft 5 in	5,30 m
Width outrigger footprint standard (J)	15 ft 7 in	4,75 m
Length footprint one side narrow (K)	21 ft 9 in	6,64 m
Width footprint one side narrow (L)	12 ft 11 in	3,95 m
Width footprint both sides narrow (M)	9 ft 10 in	2,99 m

PRODUCTIVITY	US	Metric
Basket capacity	441 lbs	200 kg
Movable jib	180°	180°
Basket rotation	180°	180°
Turret rotation	450°	450°
Stabilization, maximum ground slope	16.7°/30.0 %	16,7°/30,0 %
Height and width track adjustment	8 <sup>3</sup> / <sub>4</sub> /6 <sup>3</sup> / <sub>4</sub> in	22/17 cm
Gradeability, max.	16.7°/30.0 %	16,7°/30,0 %
Slope angle	16.7°/30.0 %	16,7°/30,0 %
Travel speed	1.9 mph	3,0 km/h

WEIGHT	US	Metric
Total weight	9,480 lbs	4.300 kg
Live load in travelling position	77.0 psf	3,7 kN/m <sup>2</sup>
Live load in working position	35.5 psf	1.7 kN/m <sup>2</sup>

POWER	
Standard power sources	<b>1) Electric:</b> 115 V, 19.3 A, 1.6 kW <b>2) Diesel:</b> Kubota D 902-E3 (16.1 kW/21.6 hp)
Optional power source	<b>Battery:</b> 80 V
Fuel tank capacity Diesel engine	10.6 gal      40,0 l

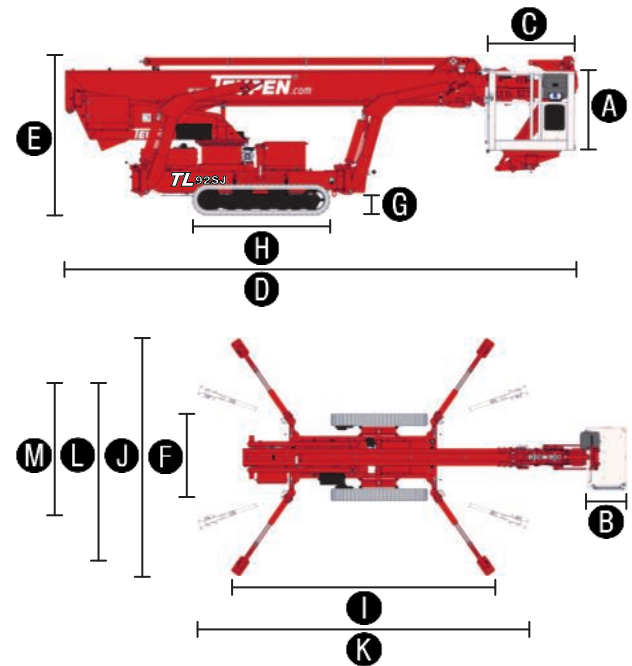

## WORKING ENVELOPE

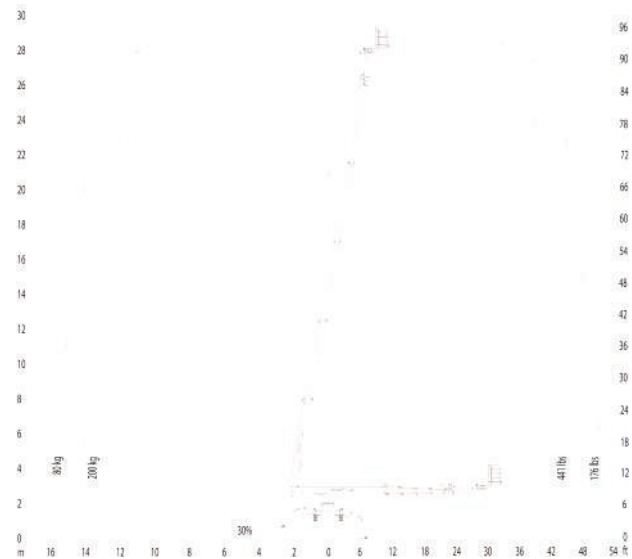

## STANDARDS COMPLIANCE



EN ISO 9001



ANSI/SIA A92.5-2006 section 4 & CSA B354.1-2004  
"Design & manufacture criteria"

Product specifications are subject to change without notice or obligation. Photographs and drawings in this document are for illustrative purposes only. Refer to the appropriate Operator's Manual for instructions on the proper use of this equipment. Failure to follow the appropriate Operator's Manual when using our equipment or to otherwise act irresponsibly may result in serious injury or death. The only warranty applicable to our equipment is the standard written warranty applicable to the particular product and sale and we make no other warranty, expressed or implied. Products and services listed may be trademarks, service marks or trade-names of Teupen Maschinenbau GmbH and/or its subsidiaries in the U.S.A. and many other countries. "Teupen", "Access redefined" and "LEO Series" are registered Trademarks of Teupen GmbH in the United States of America and many other countries. Version 2014-A © 2014 Teupen Maschinenbau GmbH.